

<b>BODY</b> 107' Tandem Axle Platform Aluminum Body <b>COMPT, DRIVER SIDE FRONT</b> FH/FD RollUp w/o Chute <b>COMPT, DRIVER SIDE REAR</b> FH/FD RollUp and Lift-up rearward <b>COMPT, PASSENGER SIDE FRONT</b> Full Height RollUp Forward <b>COMPT, PASSENGER SIDE REAR</b> Full Height RollUp and Liftup Rearward	<b>WATER TANK</b> 500 Gallon Notched Poly Water Tank <b>Foam System</b> Plumbing For Future Foam System <b>Foam Cell</b> 20 Gallon Foam Cell, Non-Reduced Water
---	--

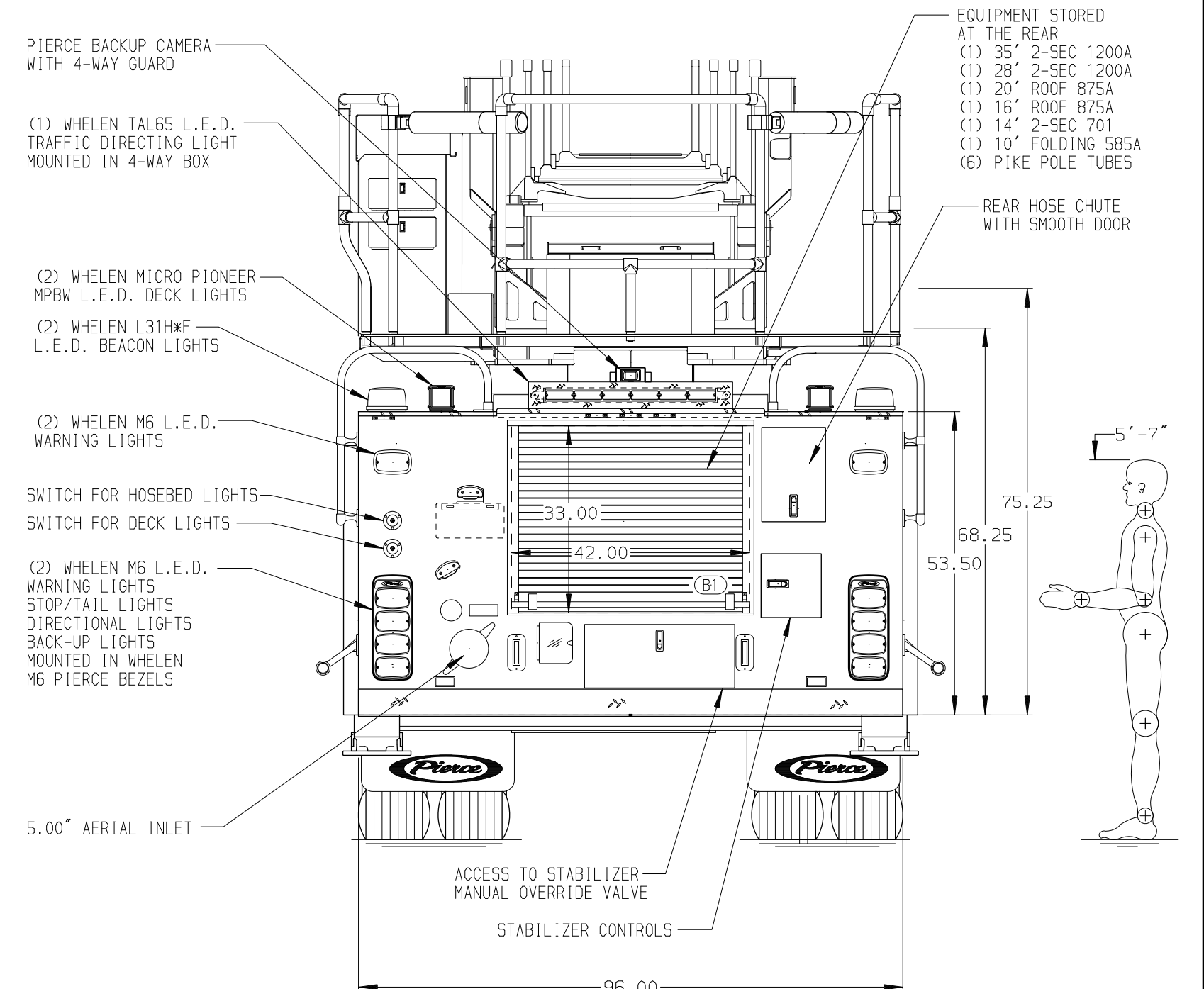
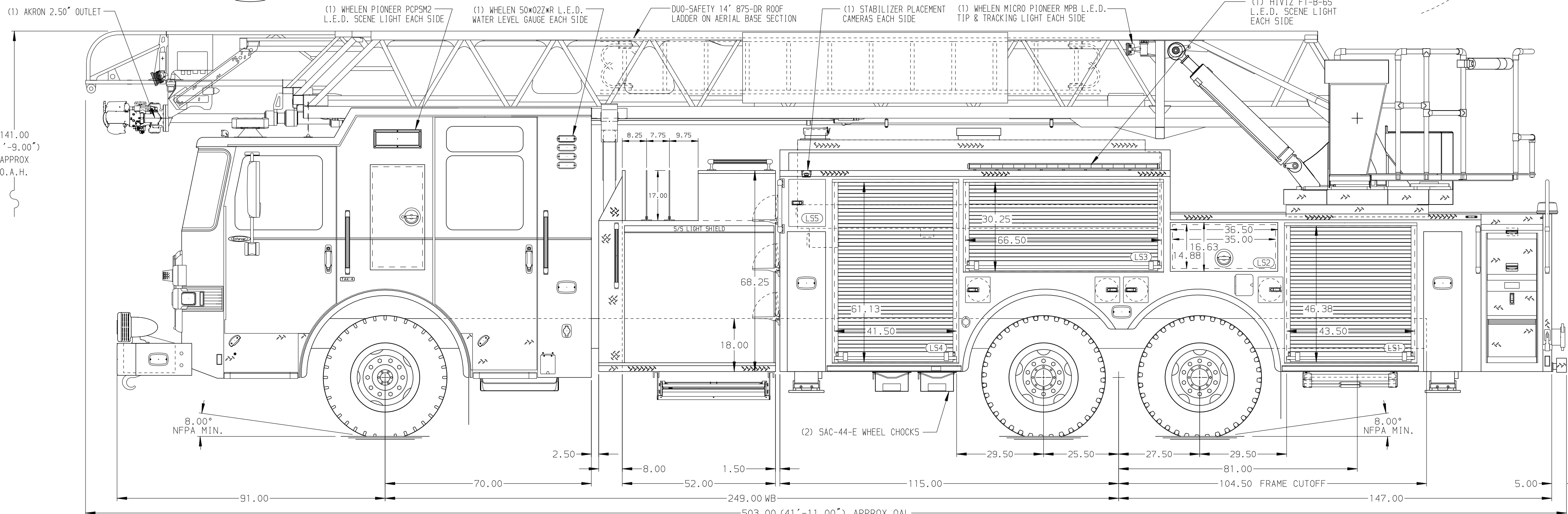

<b>CHASSIS</b> Enforcer Chassis <b>ENGINE</b> 510 HP Paccor MX13 Engine	<b>CAB</b> 7010 Enforcer Cab <b>BUMPER</b> 22" Extended Pointed Steel	<b>AXLE, FRONT, CUSTOM</b> 22,800 Lb TAK-4 Axle <b>AXLE, REAR</b> 44,000 Lb Meritor Axle	<b>TRANSMISSION</b> Allison 6th Gen, 4500 EV5 P	<b>PUMPHOUSE</b> 52" Control Zone Side Mount <b>PUMP</b> 2000 GPM Waterous CSU	<b>CROSSLAYS, 1.50"</b> (2) 1.75" Standard Capacity <b>CROSSLAYS, 2.50"</b> (1) 2.50" Standard Capacity	<b>SPEEDLAYS</b> Speedlays Not Required <b>GENERATOR</b> Generator Not Required	<b>SAFETY</b> Side Roll and Frontal Impact Protection	<b>CUSTOMER APPROVAL</b> APPROVED BY: _____ DATE: _____		JOB NO. 42555
<b>NOTE</b> DIMENSIONS SHOWN ARE APPROXIMATE AND ARE SUBJECT TO MINOR DEVIATIONS AS MAY OCCUR OR BE NECESSARY IN CONSTRUCTION. MINOR DETAILS NOT SHOWN.	1. 21.00" LIMITED RETRACTION REQUIRED 2. ONE 1.50" OUTLET WITH 2.00" PIPING AND SWIVEL LOCATED IN CENTER BUMPER TRAY 3. SHORELINE RECEPTACLE WITH KUSSMALL SUPER AUTO-EJECT LOCATED ON DRIVER SIDE OF CREW CAB 4. AIR INLET WITH DISCONNECT COUPLING LOCATED IN DRIVER SIDE STEP WELL 5. BATTERY CHARGER LOCATED BEHIND DRIVER SEAT 6. BATTERY CHARGER INDICATOR ON DRIVER'S SEAT RISER 7. FIVE ADJUSTABLE SHELVES LOCATED IN COMPARTMENTS PER ORDER 8. THREE FLOOR MOUNTED SLIDE-OUT TRAYS LOCATED IN COMPARTMENTS PER ORDER 9. ONE SWING-OUT TOOLBOARD LOCATED IN COMPARTMENT PER ORDER 10. ONE PEGBOARD MOUNTED ON COMPARTMENT BACK WALL LOCATED PER ORDER	11. ONE THREE-DRAWER CTECH CABINET LOCATED IN COMPARTMENT PER ORDER 12. TWO RECEPTACLES LOCATED PER ORDER 13. 1500 GPM HIGH FLOW WATERWAY 14. 3.00" RAISED AERIAL PEDESTAL 15. TECNIO RUNG LIGHTING AT AERIAL DEVICE 16. FIRE RESEARCH 2-WAY INTERCOM								
										TITLE 107' ASCENDANT AERIAL LADDER AND BODY ASSEMBLY
										FOR PIERCE FIELD UNIT APPLETON, WI
										CHECKED BY ASY 05APR24
										SHEET SIZE D SHEET NO. 1 OF 1
										DWG NO. 42555AD