

SURFACE DESIGNATION AND PATHWAY MARKINGS

BODY	WATER TANK
107' ASL Aluminum Body	500 Gallon Poly Water Tank
COMPT, LEFT SIDE FRONT	Foam System
Full Height RollUp Forward	Plumbing for Future Husky Foam System
COMPT, LEFT SIDE REAR	Foam Cell
Full Height RollUp Rearward	20 Gallon Foam Cell, Non Reduced Water
COMPT, RIGHT SIDE FRONT	
Full Height RollUp Forward	
COMPT, RIGHT SIDE REAR	
Full Height RollUp Rearward	

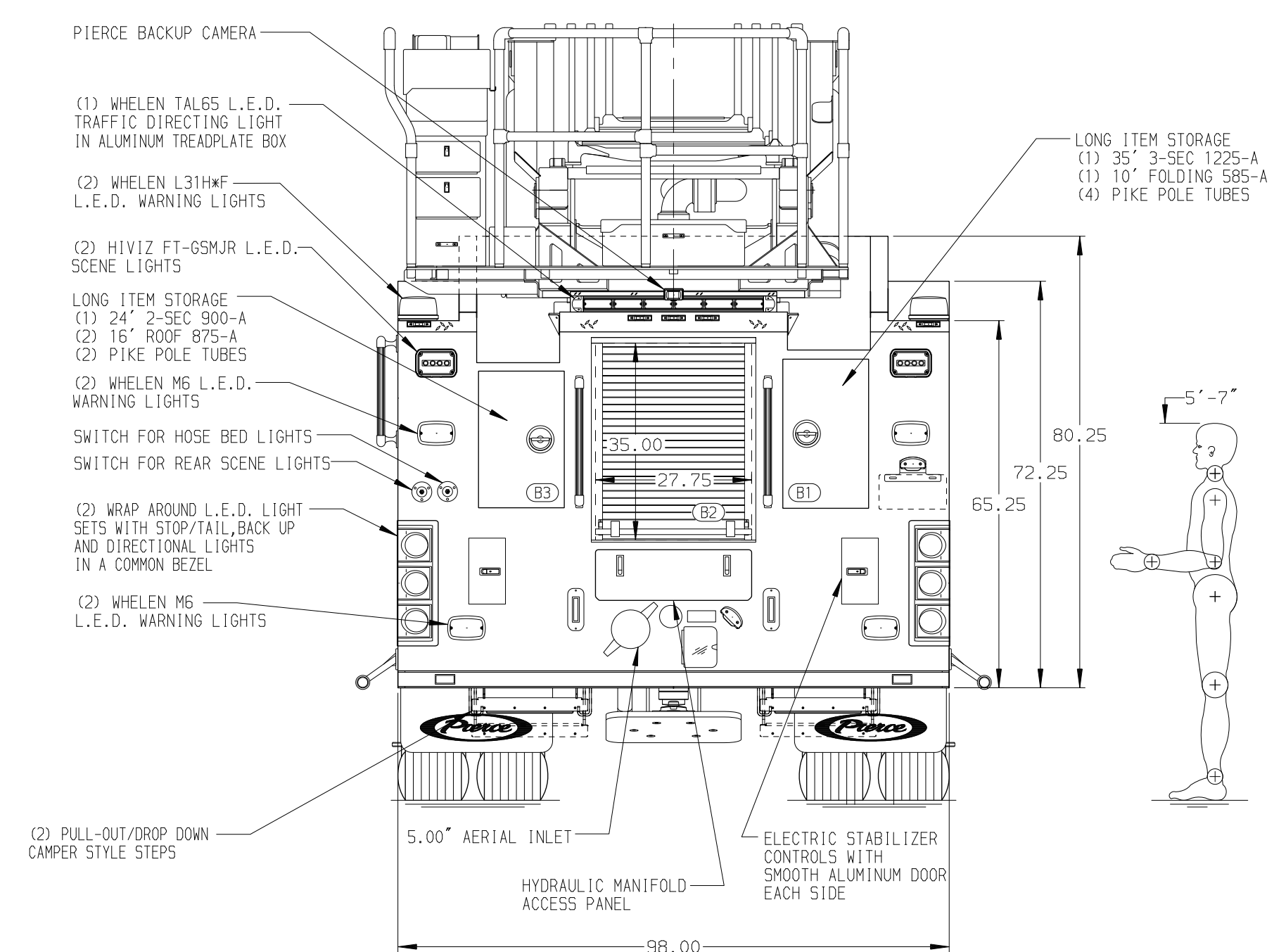
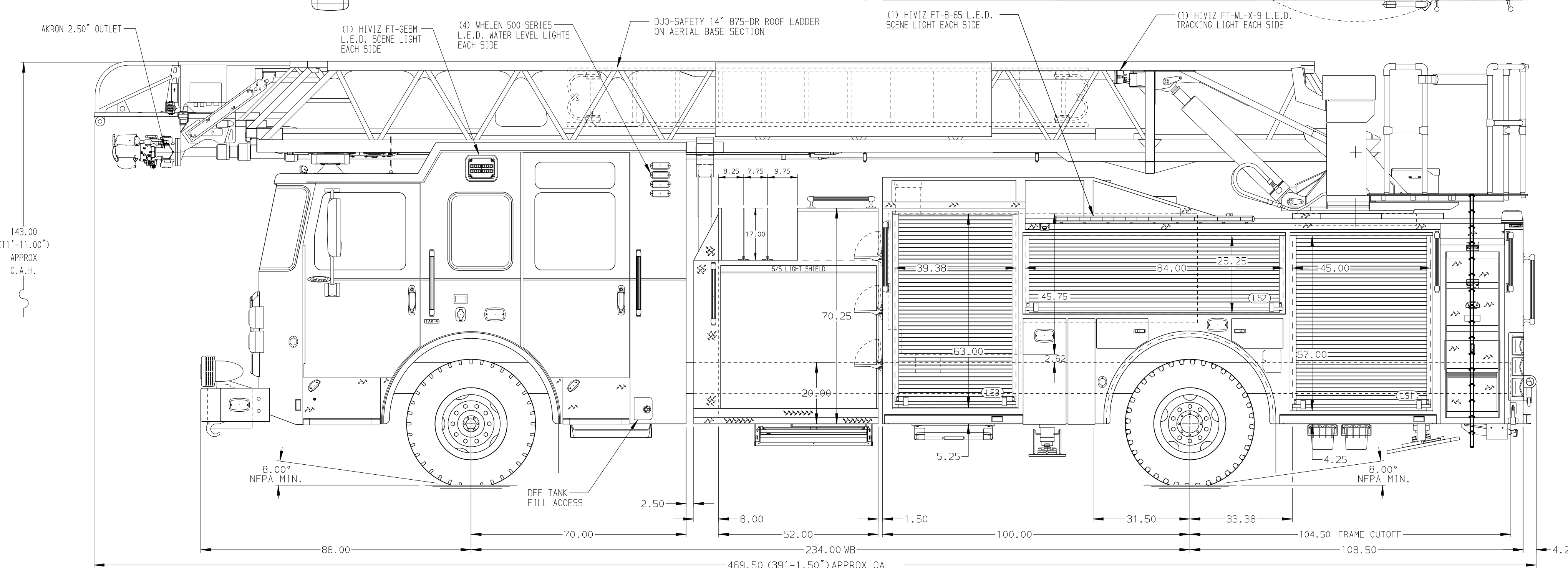

CHASSIS	CAB	AXLE, FRONT, CUSTOM	TRANSMISSION	PUMPHOUSE	CROSSLAYS, 1.50"	SPEEDLAYS	SAFETY	CUSTOMER APPROVAL	Pierce MANUFACTURING INC.		JOB NO.	
Enforcer Chassis ENGINE 510 HP Paccor MX13 Engine	7010 Enforcer Notched Cab BUMPER 19" Extended Painted Steel	22,800 Lb TAK-4 Axle AXLE, REAR 33,500 Lb Meritor Axle	Allison 6th Gen, 4000 EV5 P	52" Control Zone Side Mount PUMP 2000 GPM Watertous CSU	(2) 1.50" Standard Capacity CROSSLAYS, 2.50"	Speedlays Not Required GENERATOR Generator Not Required	Side Roll and Frontal Impact Protection	APPROVED BY: _____ DATE: _____			42453	
<b>NOTE</b> DIMENSIONS SHOWN ARE APPROXIMATE AND ARE SUBJECT TO MINOR DEVIATIONS AS MAY OCCUR OR BE NECESSARY IN CONSTRUCTION. MINOR DETAILS NOT SHOWN.											SCALE 1:24	DATE
1. SHORELINE RECEPTACLE WITH KUSSMAUL SUPER AUTO-EJECT LOCATED ON DRIVER SIDE OF THE CAB 2. AIR INLET WITH DISCONNECT COUPLING LOCATED FORWARD IN THE DRIVER SIDE STEPWELL 3. BATTERY CHARGER LOCATED BEHIND DRIVERS SEAT 4. BATTERY CHARGE INDICATOR LOCATED ON DRIVERS SIDE OF CAB 5. ONE 1.50" OUTLET WITH 2.00" PIPING AND SWIVEL LOCATED IN CENTER BUMPER TRAY 6. SIX ADJUSTABLE SHELVES LOCATED IN COMPARTMENTS PER ORDER 7. THREE FLOOR MOUNTED SLIDE-OUT TRAYS LOCATED IN COMPARTMENTS PER ORDER 8. ONE CTECH CABINET LOCATED IN COMPARTMENT PER ORDER 9. ONE RECEPTACLE LOCATED IN COMPARTMENT PER ORDER 10. DUAL L.E.D. LIGHT STRIPS LOCATED IN COMPARTMENTS PER ORDER 11. TWO RECEPTACLE STRIPS LOCATED PER ORDER 12. ONE ALUMINUM SWING-OUT TOOLBOARD LOCATED IN COMPARTMENT PER ORDER 13. ONE VERTICAL PARTITION LOCATED IN COMPARTMENT PER ORDER 14. ONE BACK WALL MOUNTED PEGBOARD LOCATED IN COMPARTMENT PER ORDER 15. 1500 GPM HIGH FLOW WATERWAY 16. LIMITED RETRACTION NOT REQUIRED 17. MOUNTING PROVISIONS FOR FRONT INLET 18. RING LIGHTING ON AERIAL LADDER 19. NON-RAISED AERIAL PEDESTAL											DRAWN BY ANZ	DATE 04MAR24
<b>FOR</b> PIERCE FIELD UNIT APPLETON, WI											CHECKED BY AST	DATE 04MAR24
<b>DWG NO.</b> 42453AD											SHEET SIZE D	SHEET NO. 1 OF 1