

<b>BODY</b> 100' Ascendant Aerial Tower Alum Body <b>COMPT, LEFT SIDE</b> Full Height & Full Depth RollUp Doors <b>COMPT, RIGHT SIDE</b> Full Height RollUp Doors	<b>WATER TANK</b> 300 Gallon Poly Water Tank <b>Foam System</b> Foam System Not Required <b>Foam Cell</b> Foam Cell Not Required
--	---

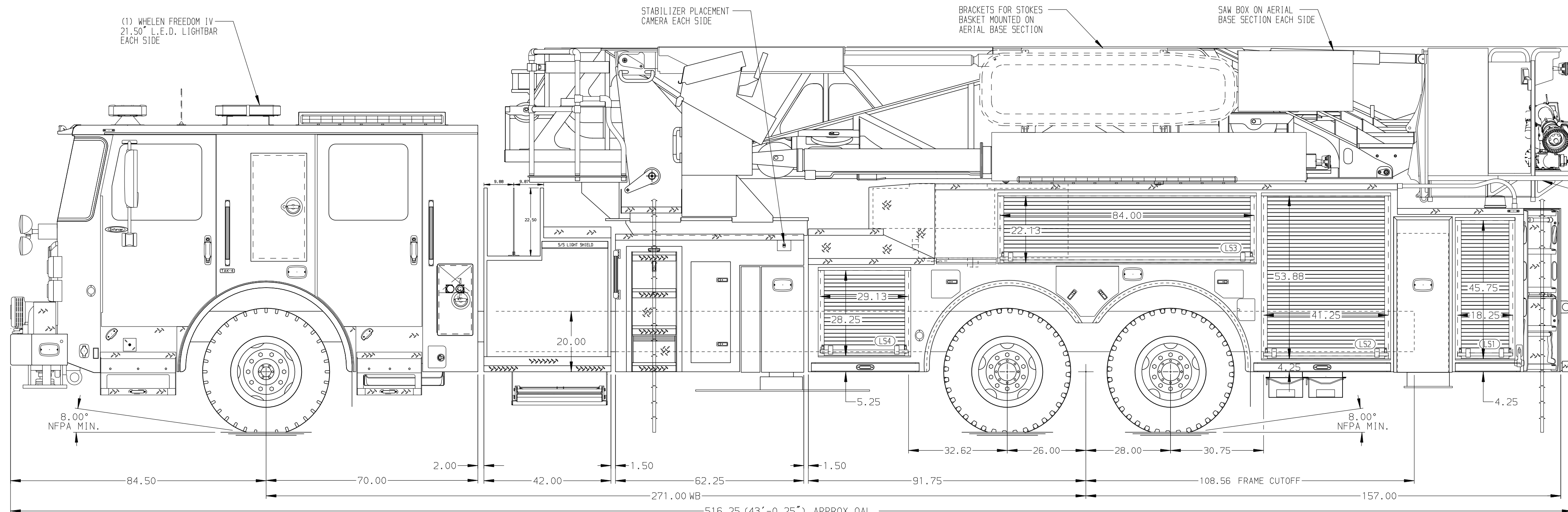

<b>CHASSIS</b> Enforcer Chassis <b>ENGINE</b> 510 HP Paccor MX13 Engine	<b>CAB</b> 7000 Enforcer Cab <b>BUMPER</b> 15" Painted Aluminum	<b>AXLE, FRONT, CUSTOM</b> 24,000 Lb TAK-4 Axle <b>AXLE, REAR</b> 54,000 Lb Meritor Axle	<b>TRANSMISSION</b> Allison 6th Gen, 4500 EV5 P	<b>PUMPHOUSE</b> 42" Control Zone Side Mount <b>PUMP</b> 2000 GPM Waterous S100	<b>CROSSLAYS, 1.50"</b> (2) 1.50" Standard Capacity <b>CROSSLAYS, 2.50"</b> 2.50" Crosslay Not Required	<b>SPEEDLAYS</b> Speedlays Not Required <b>GENERATOR</b> Generator Not Required	<b>SAFETY</b> Side Roll and Frontal Impact Protection
--	--	---	--	--	--	--	---

**NOTE**  
 DIMENSIONS SHOWN ARE APPROXIMATE AND ARE SUBJECT TO MINOR DEVIATIONS AS MAY OCCUR OR BE NECESSARY IN CONSTRUCTION. MINOR DETAILS NOT SHOWN.

- SHORELINE RECEPTACLE WITH KUSSMAUL SUPER AUTO-EJECT LOCATED ON DRIVER CAB CORNER
- AIR INLET WITH DISCONNECT COUPLING RECESSED IN THE DRIVER SIDE STEPWELL
- BATTERY CHARGER LOCATED PER ORDER
- NINE ADJUSTABLE SHELVES LOCATED PER ORDER
- NON-RAISED AERIAL PEDESTAL
- 3-IN-1 LYFCOMBO BRACKETS AT AERIAL BASKET
- FOUR SLIDE-OUT TRAYS PER ORDER
- THREE FLOOR MOUNTED SLIDE-OUT TRAYS PER ORDER
- TWO 120V RECEPTACLE STRIPS PER ORDER
- RUNG LIGHTING ON AERIAL LADDER PER ORDER

11. DC POWER TO AERIAL TIP

		JOB NO.	41482
		SCALE	DATE
TITLE	100' ASCENDANT AERIAL TOWER AND BODY ASSEMBLY	DRAWN BY	LWE 040CT23
FOR	CITY OF WYOMING FIRE DEPARTMENT WYOMING, MI	CHECKED BY	NAK 060CT23
DWG NO.	41482AD	SHEET SIZE	SHEET NO.
		D	1 OF 1

REV	DATE	BY	CH	ENFORCER
15DEC23	LWE	ZWE		PIERCE
14DEC23	LWE	ZWE		MODEL