

HOSEBED CAPACITIES

① 1000' OF 5.00" D.J. POLY HOSE

② 1000' OF 3.00" D.J. POLY HOSE

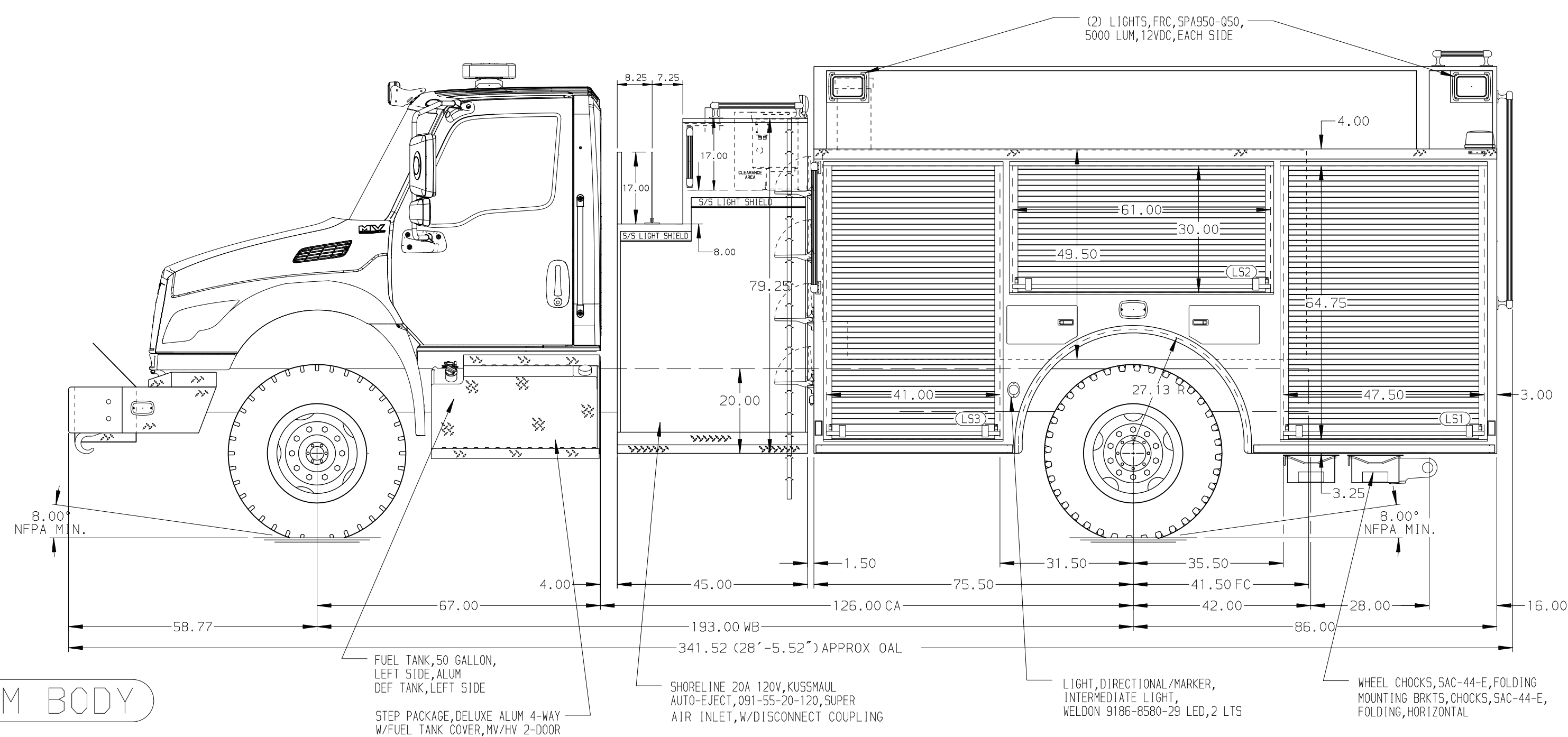

ALUMINUM BODY

NOTE
DIMENSIONS SHOWN ARE APPROXIMATE AND ARE SUBJECT TO MINOR DEVIATIONS AS MAY OCCUR OR BE NECESSARY IN CONSTRUCTION. MINOR DETAILS NOT SHOWN.

				CHASSIS DATA	TITLE	1500-D-980P, 20 FOAM 161" BDY, FL HGT FDLER, 45" SIDE CONTROL, (2) 1.5" SPEEDLAYS, 3" DELUGE	JOB NO.	39714		
				MAKE	FOR	PIERCE FIELD UNIT	SCALE	1:24	DATE	
				IHC	MODEL	APPLETON, WISCONSIN	DRAWN BY	RWR	28NOV23	
10MAY24	RWR	JAP			DWG NO.	39714AD	CHECKED BY	AJA	29NOV23	
24JAN23	RWR	AJA					SHEET SIZE	D	SHEET NO.	1 OF 1
REV	DATE	BY	CH	MV						

