

130.00  
(10'-10")  
APPROX  
O.A.H.

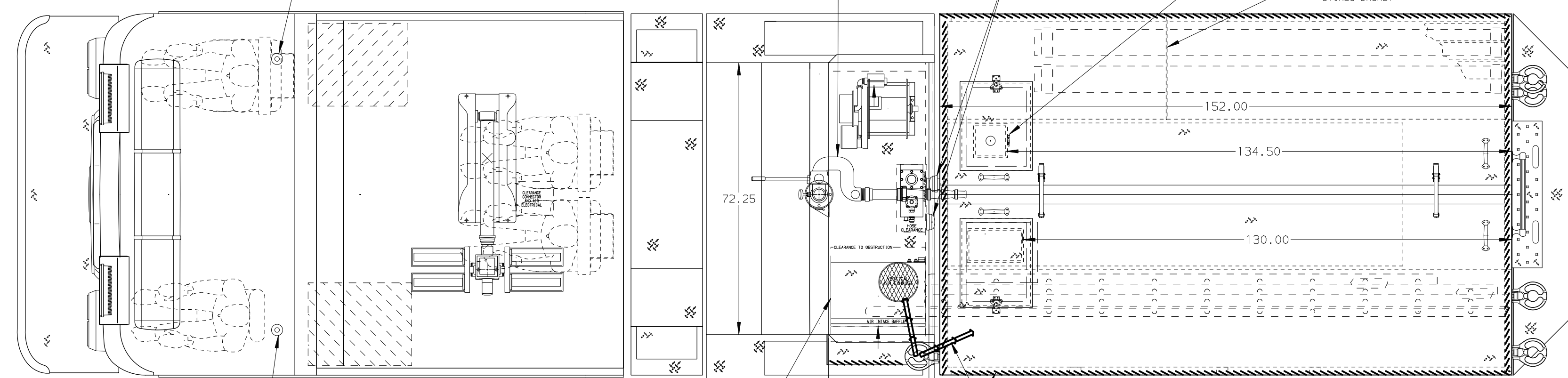
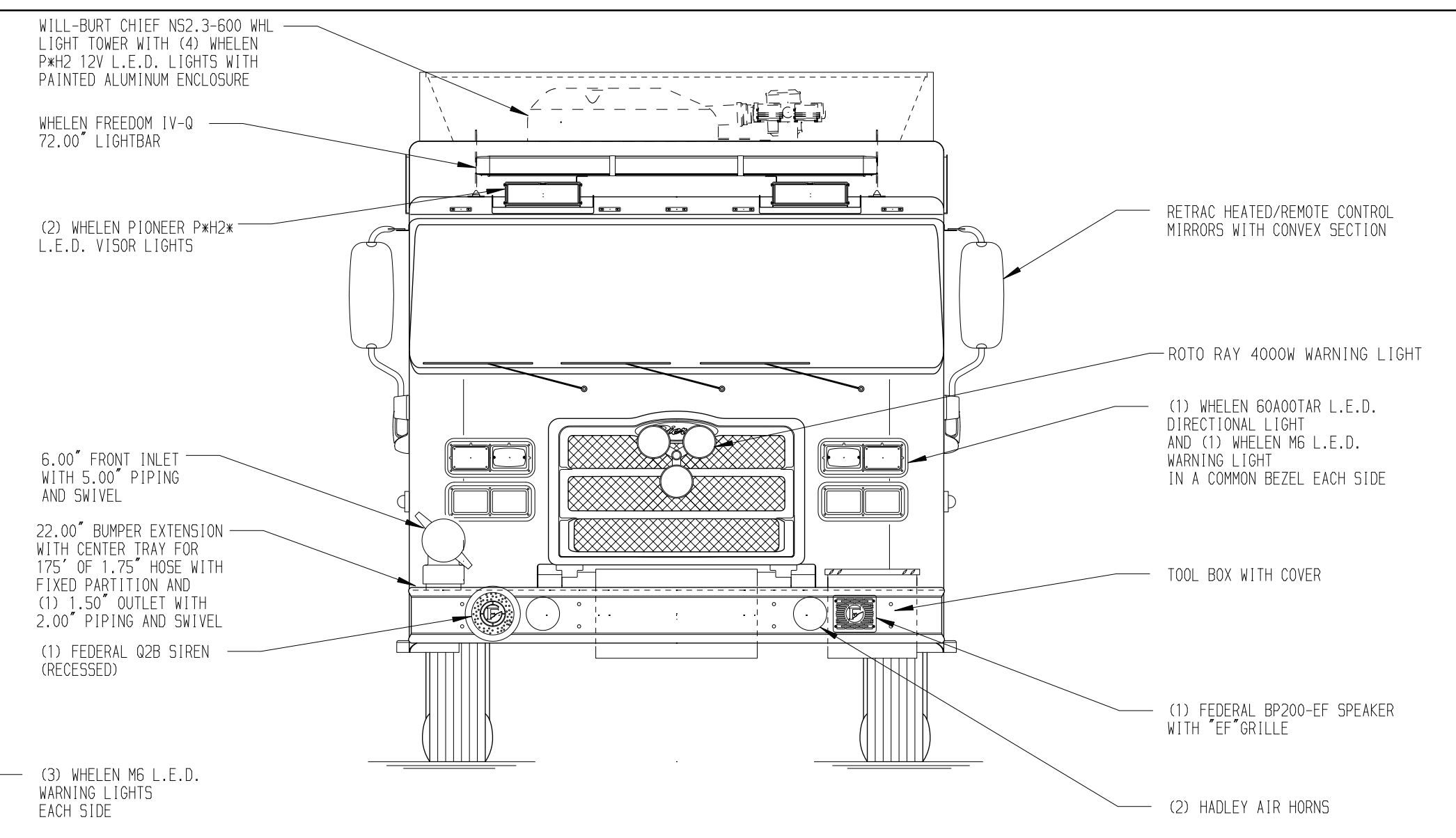
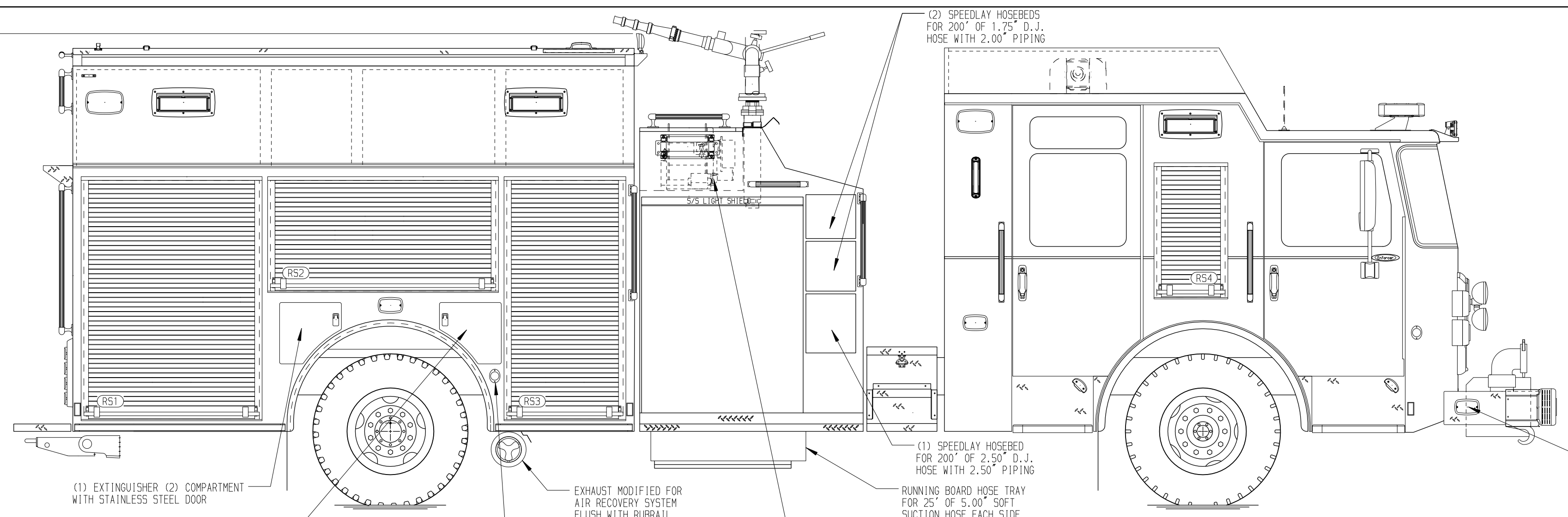

HOSEBED CAPACITIES

① 700' OF 3.00" D.J. HOSE  
200' OF 1.75" D.J. HOSE

② 1500' OF 5.00" D.J. HOSE

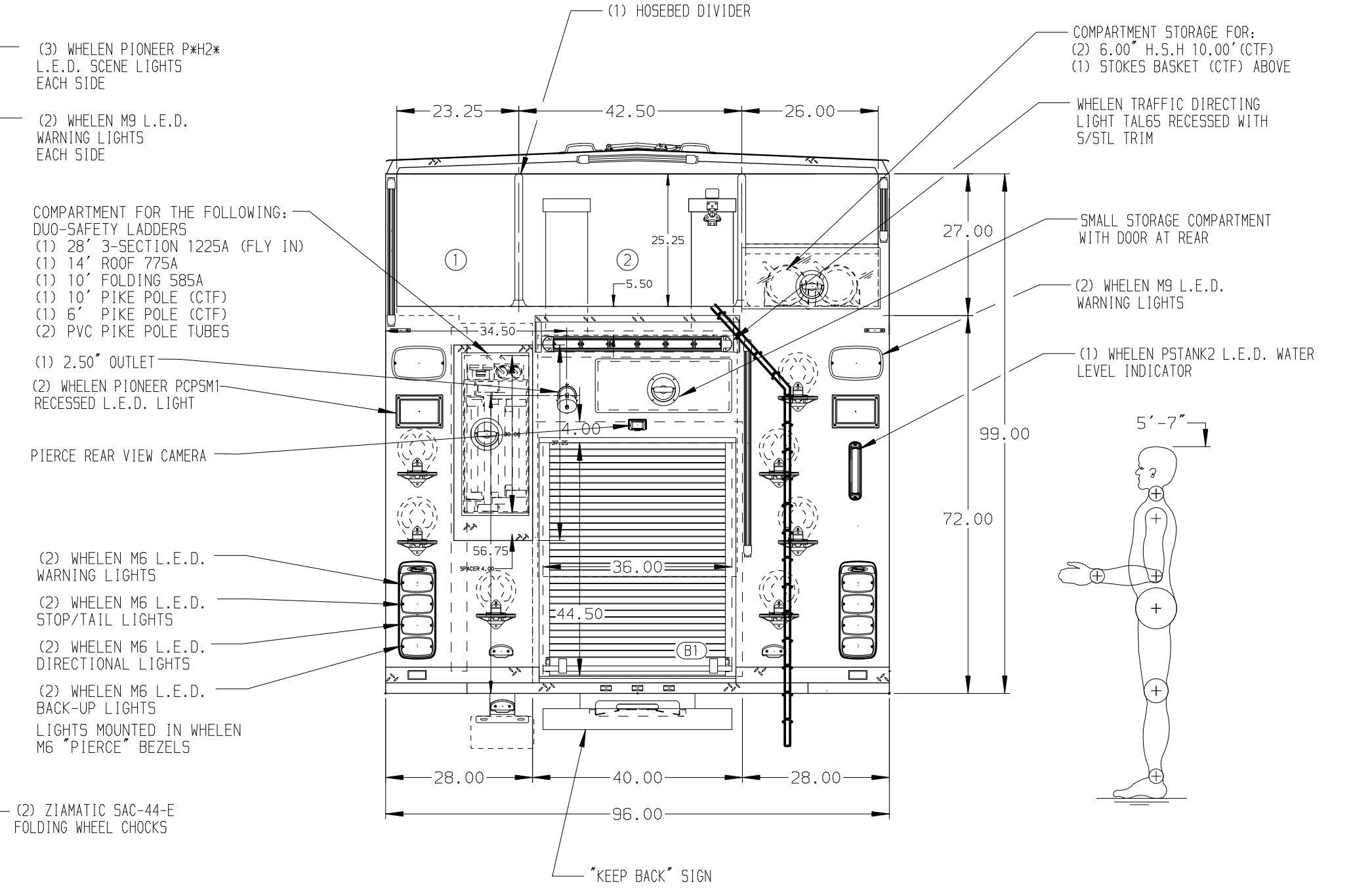
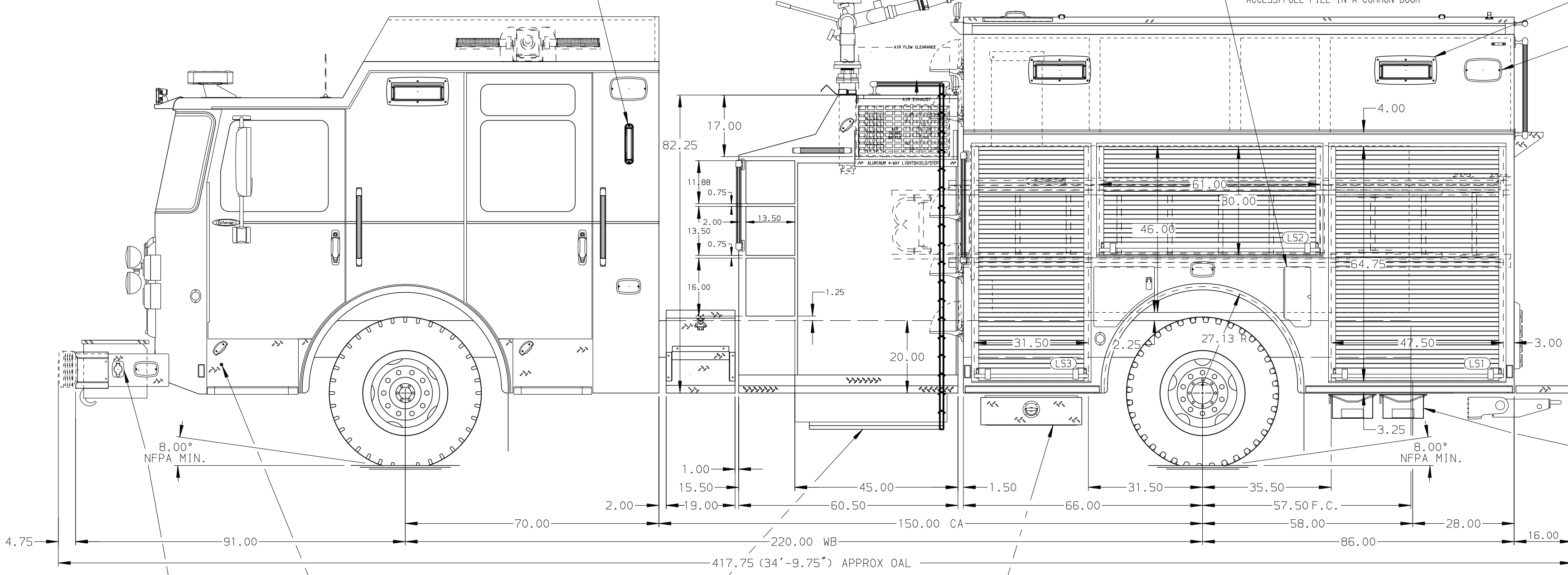

ALUMINUM BODY

SIDE ROLL & FRONTAL IMPACT PROTECTION

NOTE  
DIMENSIONS SHOWN ARE APPROXIMATE AND ARE SUBJECT TO MINOR DEVIATIONS AS MAY OCCUR OR BE NECESSARY IN CONSTRUCTION. MINOR DETAILS NOT SHOWN.

- BATTERY CHARGER/ AIR COMPRESSOR LOCATED IN COMPARTMENT L53
- BATTERY CHARGE INDICATOR LOCATED ON DRIVER'S SEAT RISER
- CIRCUIT BREAKER PANEL IN COMPARTMENT L53
- ONE WHELEN MODEL 600CEL2R LIGHT IN THE FRONT OF THE HOSE BED

REV	DATE	BY	CH	ENFORCER
24JUN24	LST	CLM		
14JUN24	LST	CLM		
22MAY24	LST	CLM		

		JOB NO.	39409
		SCALE	DATE
TITLE 1500 GPM, 765GAL TANK, 750GAL WATER, 15GAL FOAM 152" BODY, HARD WIRED FOR LIBERTYVILLE FIRE DEPARTMENT LIBERTYVILLE, ILLINOIS	DRAWN BY	LST	21MAR24
	CHECKED BY	EGO	27MAR24
DWG NO.	39409AD		SHEET NO.
			1 OF 1