

RIGHT SIDE COMPARTMENTS CONTAIN THE FOLLOWING:

COMPARTMENT RS1 CONTAINS:

- (2) SHELF, ADJUSTABLE, 500 LB CAP., STD DEPTH COMPT
- (1) TRAY, FLOOR MOUNT, SLIDE-OUT, 500 LB, 2 SIDES
- (1) TOOLBOARD, 188 ALUM, SLIDE OUT, FLOOR MTD, 500 LB CAPACITY
- (1) DIVIDER, VERTICAL

COMPARTMENT RS2 CONTAINS:

- (2) TRAY, SLIDE OUT, 1/2, TRANSVERSE COMPT, ADJUSTABLE HEIGHT, 500 LB CAPACITY
- (2) TRAY, SLIDE OUT, TILT 30°, 1/2 DEPTH OF TRANSVERSE COMPT, 200+ CAPACITY
- (1) DIVIDER, VERTICAL

COMPARTMENT RS4 CONTAINS:

- (1) TRAY, SLIDE OUT, TILT 30°, 1/2 DEPTH OF TRANSVERSE COMPT, 200+ CAPACITY
- (1) TRAY, FLOOR MOUNT, SLIDE-OUT, 500 LB, 2 SIDES
- (1) TRAY, SLIDE OUT, 1/2, TRANSVERSE COMPT, ADJUSTABLE HEIGHT, 500 LB CAPACITY

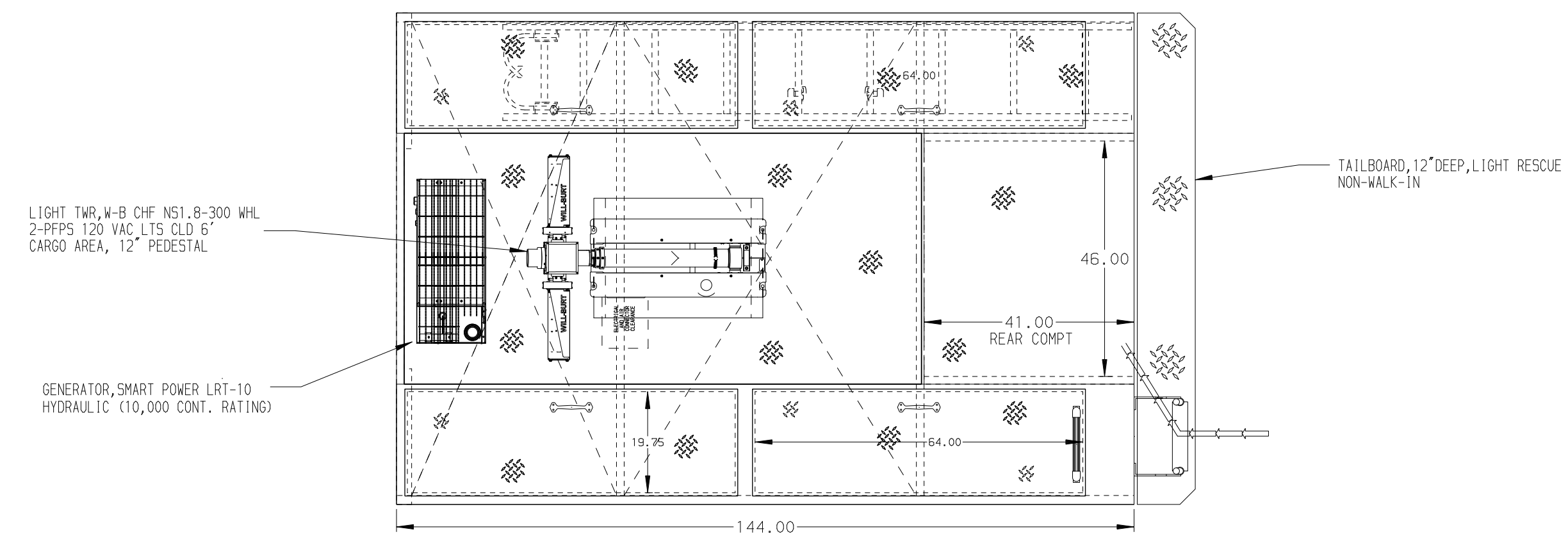
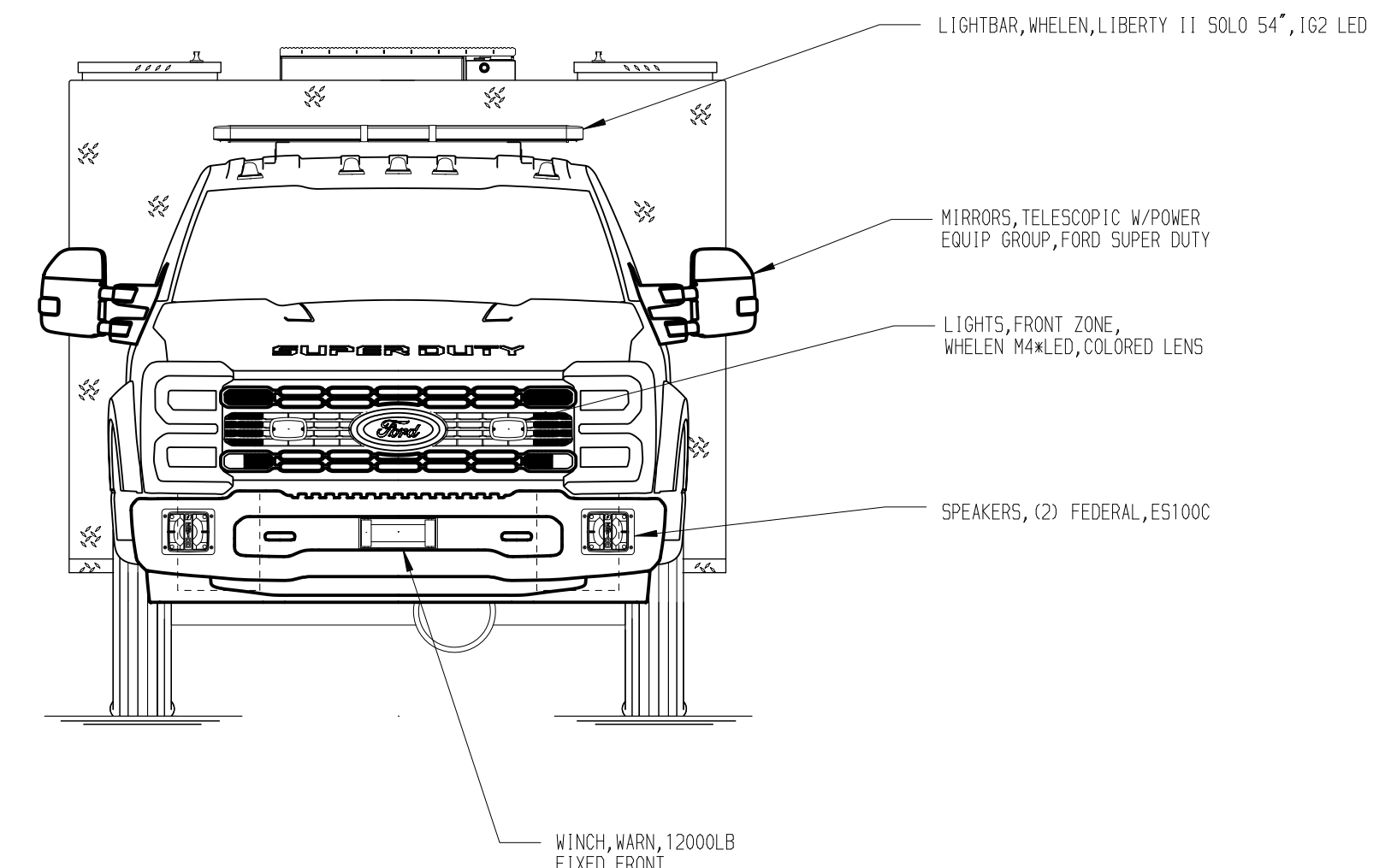
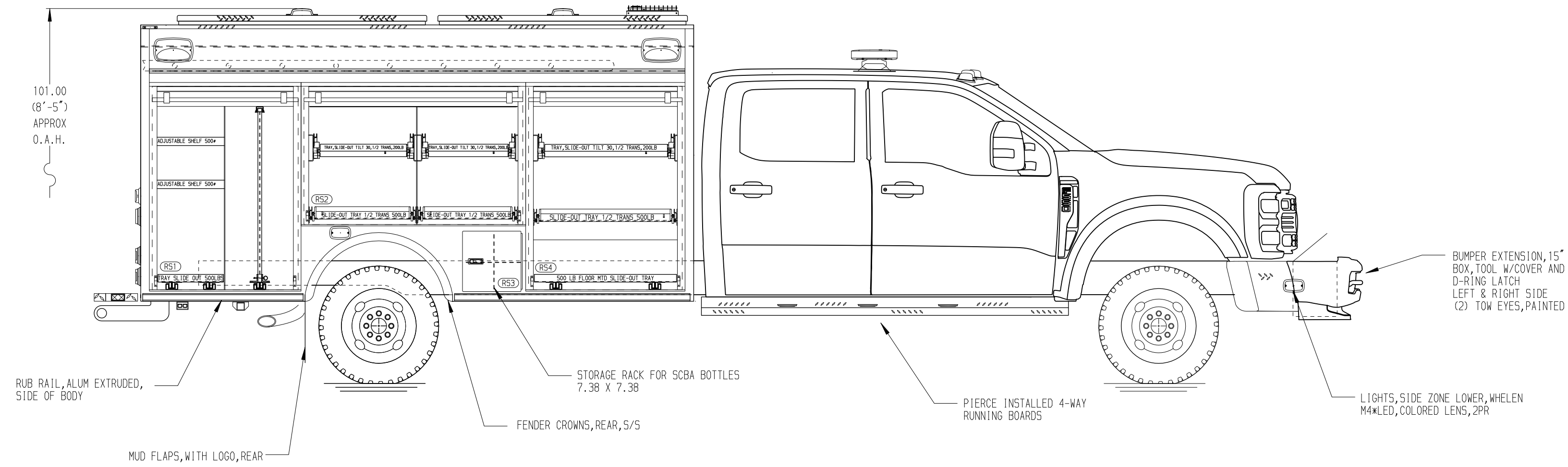

REAR COMPARTMENT B1 CONTAINS THE FOLLOWING:

COMPARTMENT B1 CONTAINS:

- (1) TRAY SLIDE OUT, FULL DEPTH, FLOOR MOUNTED, 500+ CAPACITY
- (1) TRAY, SLIDE-OUT FULL DEPTH, B1 COMPT, ADJUSTABLE HEIGHT, 500LB CAPACITY

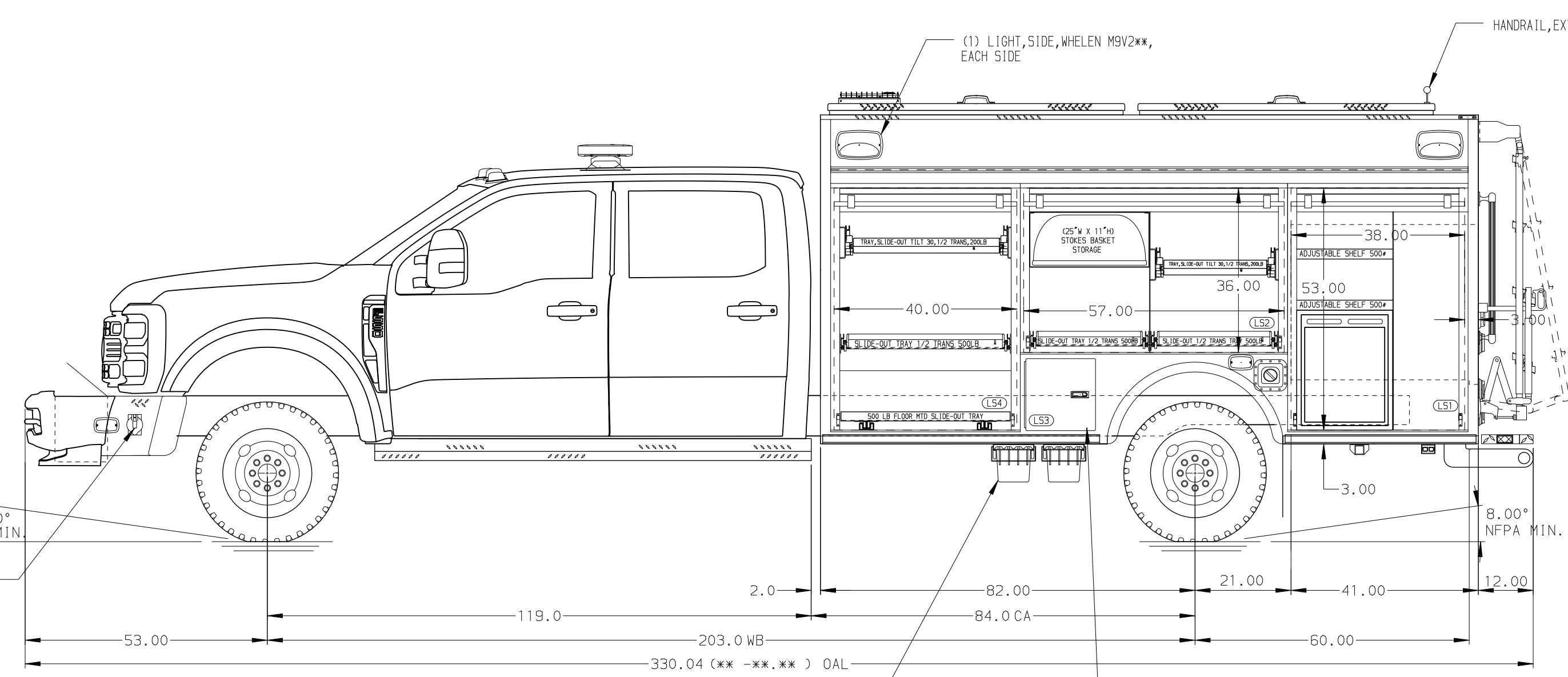

LEFT SIDE COMPARTMENTS CONTAIN THE FOLLOWING:

COMPARTMENT LS1 CONTAINS:

- (1) DIVIDER, VERTICAL
- (2) SHELF, ADJUSTABLE, 500 LB CAP., STD DEPTH COMPT
- (2) AIR BOTTLE HOLDER WITH TRACKS
- (1) REFRIGERATOR, DOMETIC CRX-1080-5 SPACE SAVER, 2.6cf, AC/DC
- (2) AIR PACKS, HELMET STORAGE AND (4) COAT HOOKS, SHIPPED LOOSE

COMPARTMENT LS2 CONTAINS:

- (1) RACK, STOKES BASKET STORAGE CHC SPLIT STRETCHER STORED SPLIT AND STACKED TOGETHER (25 M X 11" H X 47" L)
- (2) TRAY, SLIDE OUT, 1/2, TRANSVERSE COMPT, ADJUSTABLE HEIGHT, 500 LB CAPACITY
- (1) TRAY, SLIDE OUT, TILT 30°, 1/2 DEPTH OF TRANSVERSE COMPT, 200+ CAPACITY
- (1) DIVIDER, VERTICAL

COMPARTMENT LS4 CONTAINS:

- (1) TRAY, SLIDE OUT, 1/2, TRANSVERSE COMPT, ADJUSTABLE HEIGHT, 500 LB CAPACITY
- (1) TRAY, SLIDE OUT, TILT 30°, 1/2 DEPTH OF TRANSVERSE COMPT, 200+ CAPACITY
- (1) TRAY, FLOOR MOUNT, SLIDE-OUT, 500 LB, 2 SIDES

ALUMINUM BODY

NOTE
DIMENSIONS SHOWN ARE APPROXIMATE AND ARE SUBJECT TO MINOR DEVIATIONS AS MAY OCCUR OR BE NECESSARY IN CONSTRUCTION. MINOR DETAILS NOT SHOWN.

		JOB NO.	39104
		DATE	SCALE 1:24
TITLE	12' RESCUE, NON-WALK-IN	04OCT23	DRAWN BY JLA
FOR	FORT ATKINSON FIRE DEPARTMENT FORT ATKINSON, WISCONSIN	05OCT23	CHK'D BY AJA
REV.	DATE BY CHK'D	SHEET NO.	SHEET SIZE
		1 OF 1	D

11MAR24	RWR	CCS	CHASSIS DATA
11MAR24	RWR	CCS	CHASSIS
23JAN24	WHO	CCS	FORD
21NOV23	JLA	AJA	MODEL F-550 4X4

DRWG. NO. 39104AD