

RIGHT SIDE COMPARTMENTS CONTAIN THE FOLLOWING:

COMPARTMENT RS1 CONTAINS:
 - (1) RACK FOR 21 SCBA BOTTLES
 - (2) VERTICAL COMPARTMENT DIVIDERS
 - (3) STD DEPTH ADJ SHELVES

COMPARTMENT RS2 CONTAINS:
 - (1) BAUER BREATHING AIR COMPRESSOR
 -

COMPARTMENT RS3 CONTAINS:
 - (1) HIGH PRESSURE AIR REEL WITH 300' OF HOSE
 - (1) 2-WAY ADJ SLIDE OUT TRAY
 - (1) 1/2 DEPTH ADJ SLIDE OUT/TILT TRAY

COMPARTMENT RS4 CONTAINS:
 - (1) HORIZONTAL FLOOR EXTENSION

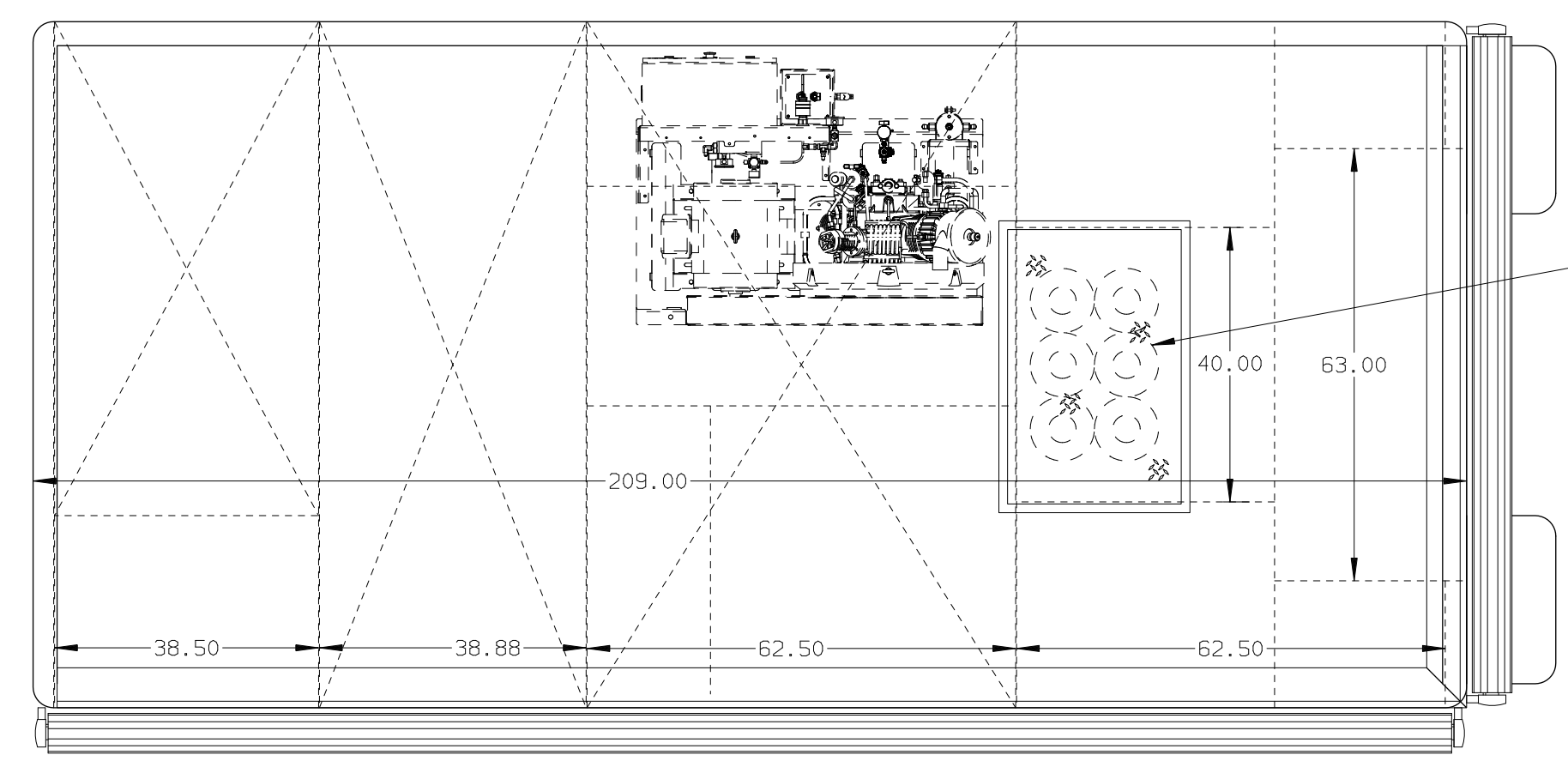
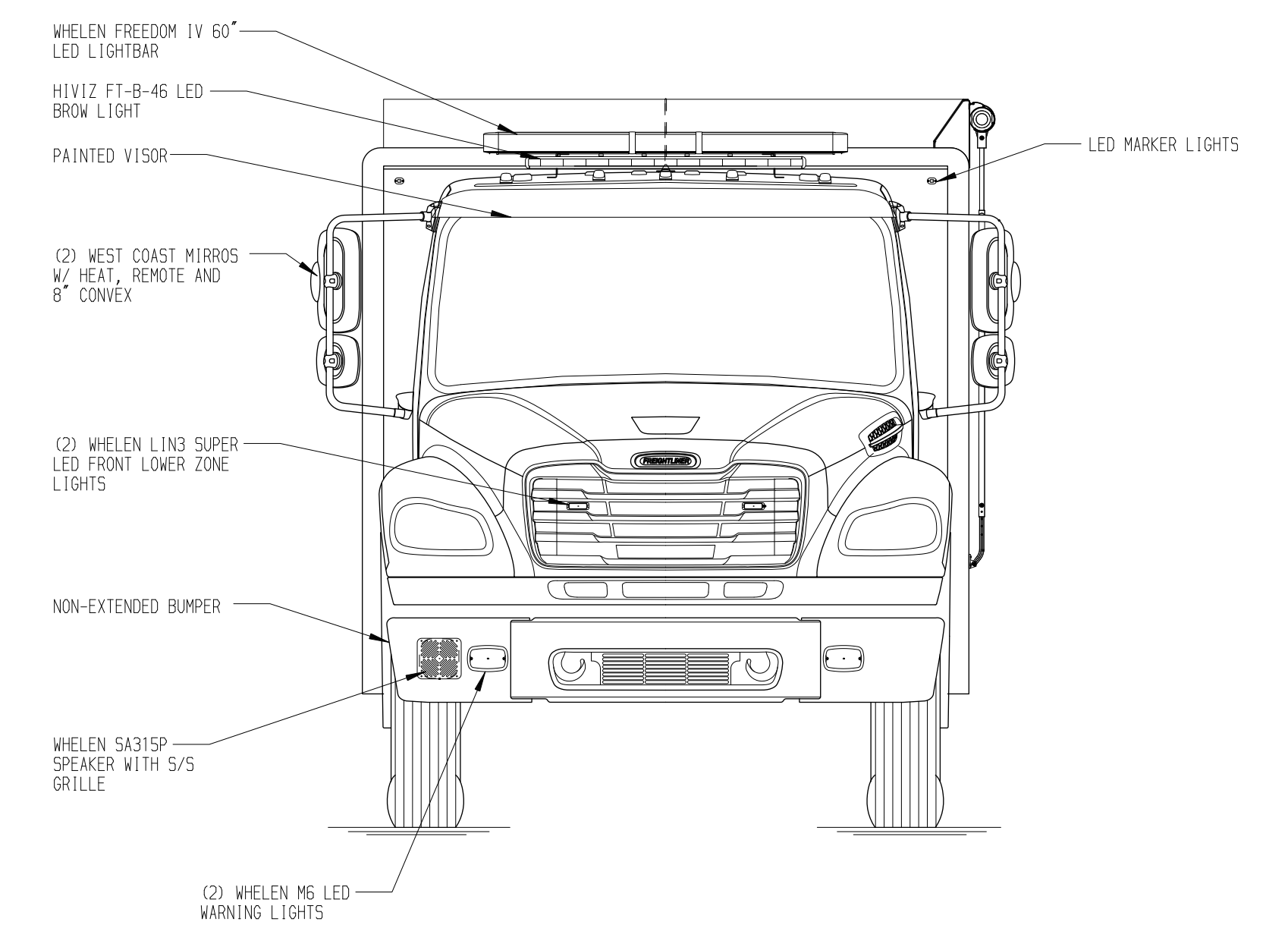
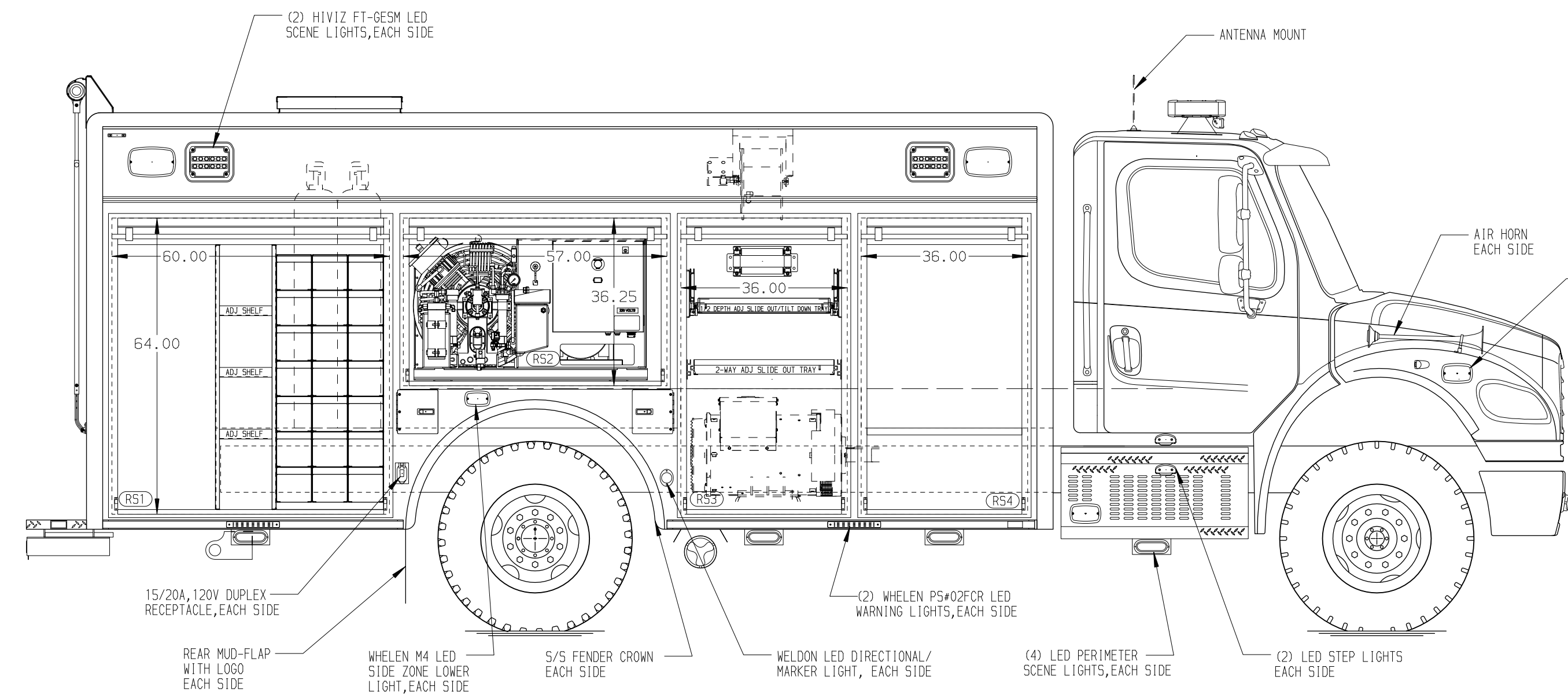

REAR COMPARTMENT CONTAINS THE FOLLOWING:

COMPARTMENT B1 CONTAINS:
 - (1) CASCADE SYSTEM CONTROL PANEL
 - (2) BAUER CP55.5-2M FILL ENCLOSURES

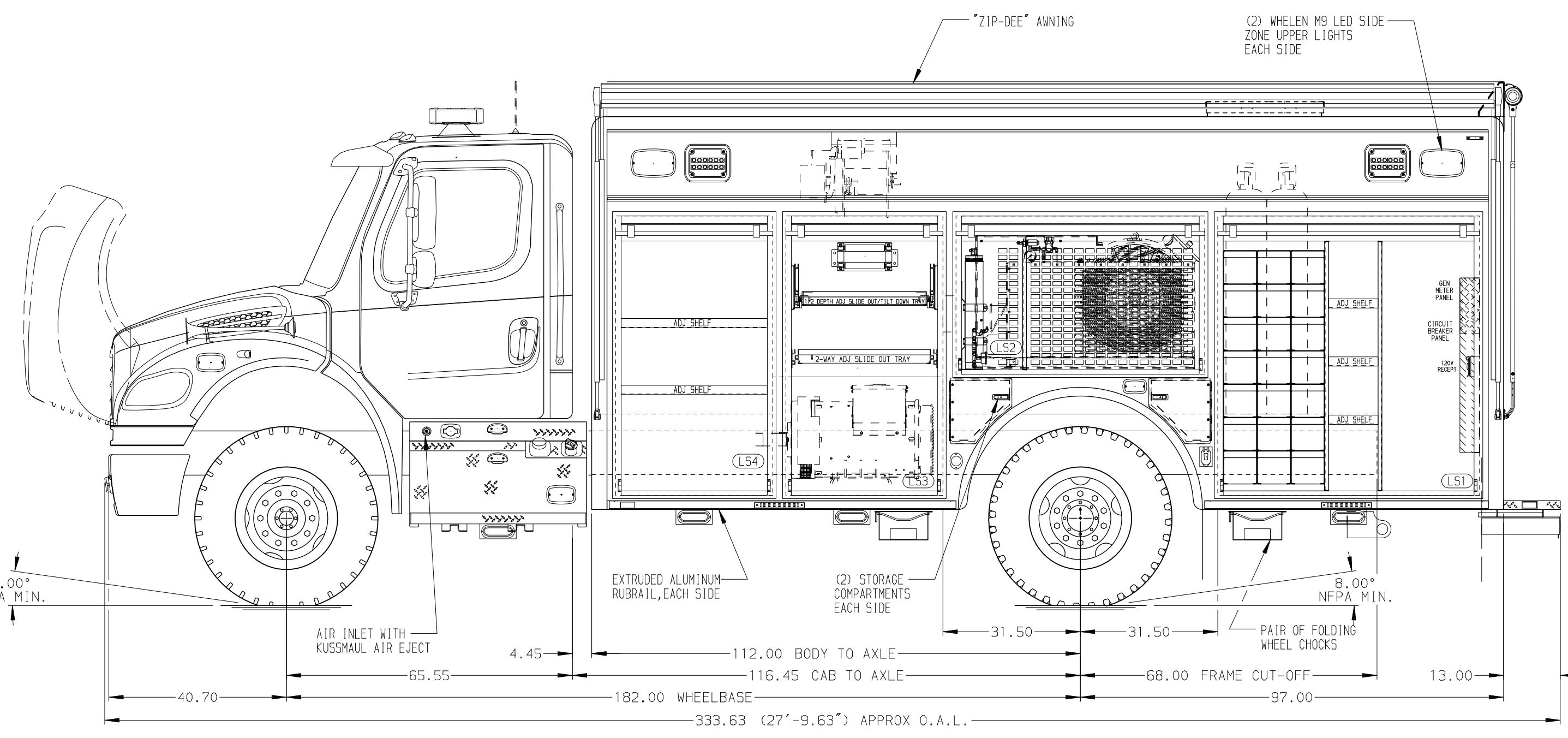

LEFT SIDE COMPARTMENTS CONTAIN THE FOLLOWING:

COMPARTMENT LS1 CONTAINS:
 - (1) RACK FOR 21 SCBA BOTTLES
 - (2) VERTICAL COMPARTMENT DIVIDERS
 - (3) STD DEPTH ADJ SHELVES
 - (1) CIRCUIT BREAKER PANEL
 - (1) GENERATOR METER PANEL
 - (1) 15/20A, 120V DUPLEX RECEPTACLE

COMPARTMENT LS2 CONTAINS:
 - (1) BAUER BREATHING AIR COMPRESSOR
 - BREATHING AIR PURIFIERS
 - REAR WALL DIVIDER WITH KNOCKOUTS
 - (1) L-SHAPED VERTICAL DIVIDER

COMPARTMENT LS3 CONTAINS:
 - (1) 2-WAY ADJ SLIDE OUT TRAY
 - (1) 1/2 DEPTH ADJ SLIDE OUT/TILT TRAY
 - (1) ELECTRIC CORD REEL WITH 200' OF 10/4 YELLOW CORD

COMPARTMENT LS4 CONTAINS:
 - (1) KUSSMAUL PUMP PLUS 1200 CHARGER
 - (1) VERTICAL REAR WALL DIVIDER
 - (2) STD DEPTH ADJ SHELVES

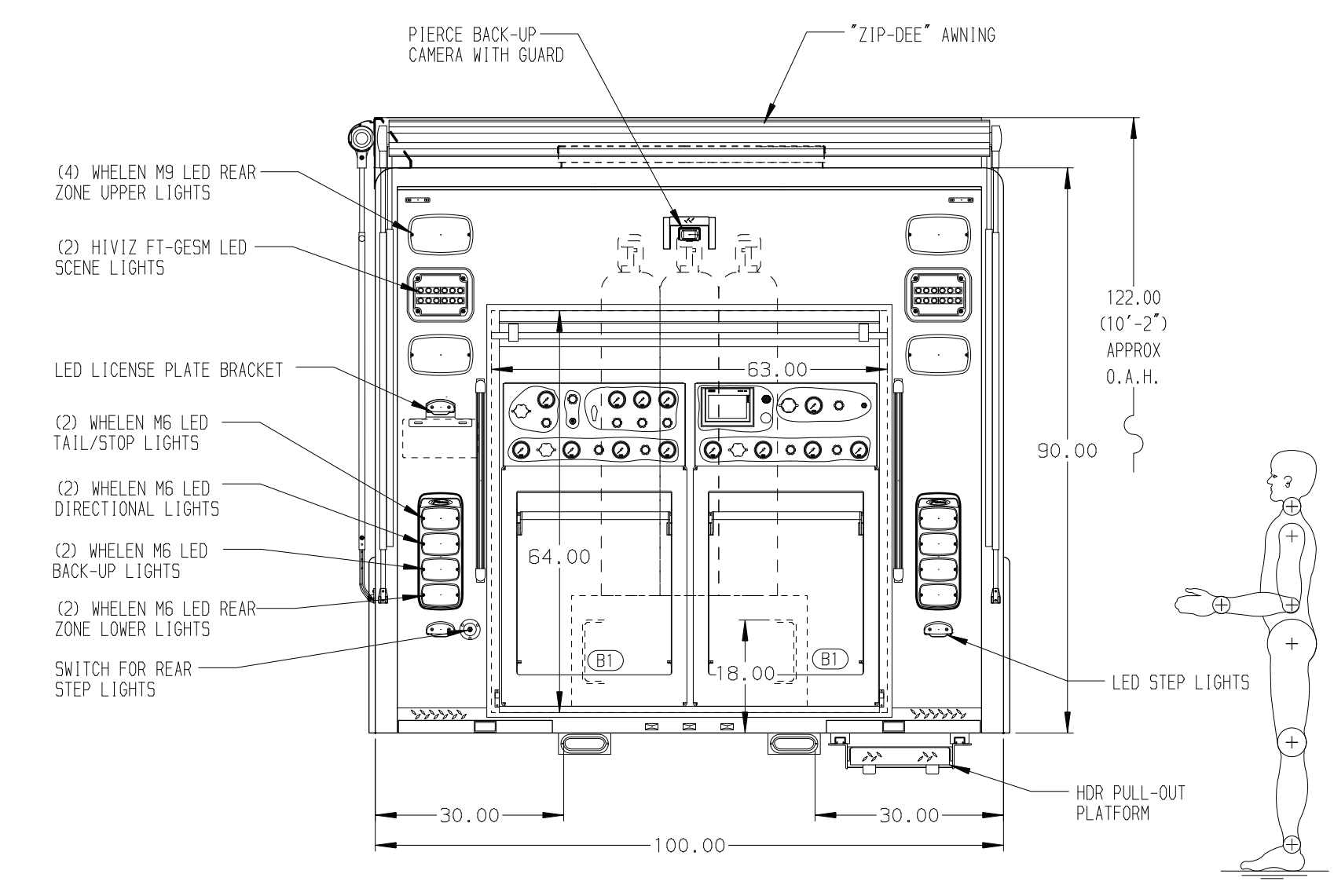

NOTE
 DIMENSIONS SHOWN ARE APPROXIMATE AND ARE SUBJECT TO MINOR DEVIATIONS AS MAY OCCUR OR BE NECESSARY IN CONSTRUCTION. MINOR DETAILS NOT SHOWN.

NOTES:
 1. ONSPOT AUTOMATIC TIRE CHAINS
 2. BATTERY CHARGE INDICATOR LOCATED ON DRIVER'S SEAT RISER
 3. PULL-STRAPS ON ALL BODY ROLL-UP DOORS
 4. PIERCE LED LIGHTS IN ALL BODY COMPARTMENTS
 5. MAGNAPLUS 80kW THREE PHASE PTO DRIVEN GENERATOR LOCATED BETWEEN THE FRAME RAILS

SIDE ROLL PROTECTION

REV	DATE	BY	CH	CHASSIS DATA
1	18SEP24	DHE	CDK	MAKE
2	08JUL24	DHE	CDK	FREIGHTLINER
3	03MAY24	DHE	CDK	MODEL
4	01MAR24	DHE	CDK	M2-106

		JOB NO.	39047
		SCALE	DATE
MANUFACTURING INC.		DRAWN BY	30JAN24
TITLE HEAVY DUTY RESCUE NON-WALKIN FOR RALEIGH FIRE DEPARTMENT BID #1125 WADE FARRIOR		CHECKED BY	07FEB23
DWG NO. 39047AD		SHEET SIZE	SHEET NO.
		D	1 OF 1