

- HOSEBED CAPACITIES**
- ① 200' OF 3.00" D.J. POLY HOSE TRAY DIM (INSIDE): 6.00" W X 25.00" H
 - ② 800' OF 4.00" D.J. POLY HOSE
 - ③ 800' OF 4.00" D.J. POLY HOSE
 - ④ 400' OF 3.00" D.J. POLY HOSE
 - ⑤ 200' OF 1.75" D.J. POLY HOSE TRAY DIM (INSIDE): 7.50" W X 10.75" H X 82.00" L
 - ⑥ 200' OF 1.75" D.J. POLY HOSE TRAY DIM (INSIDE): 7.50" W X 10.75" H X 82.00" L

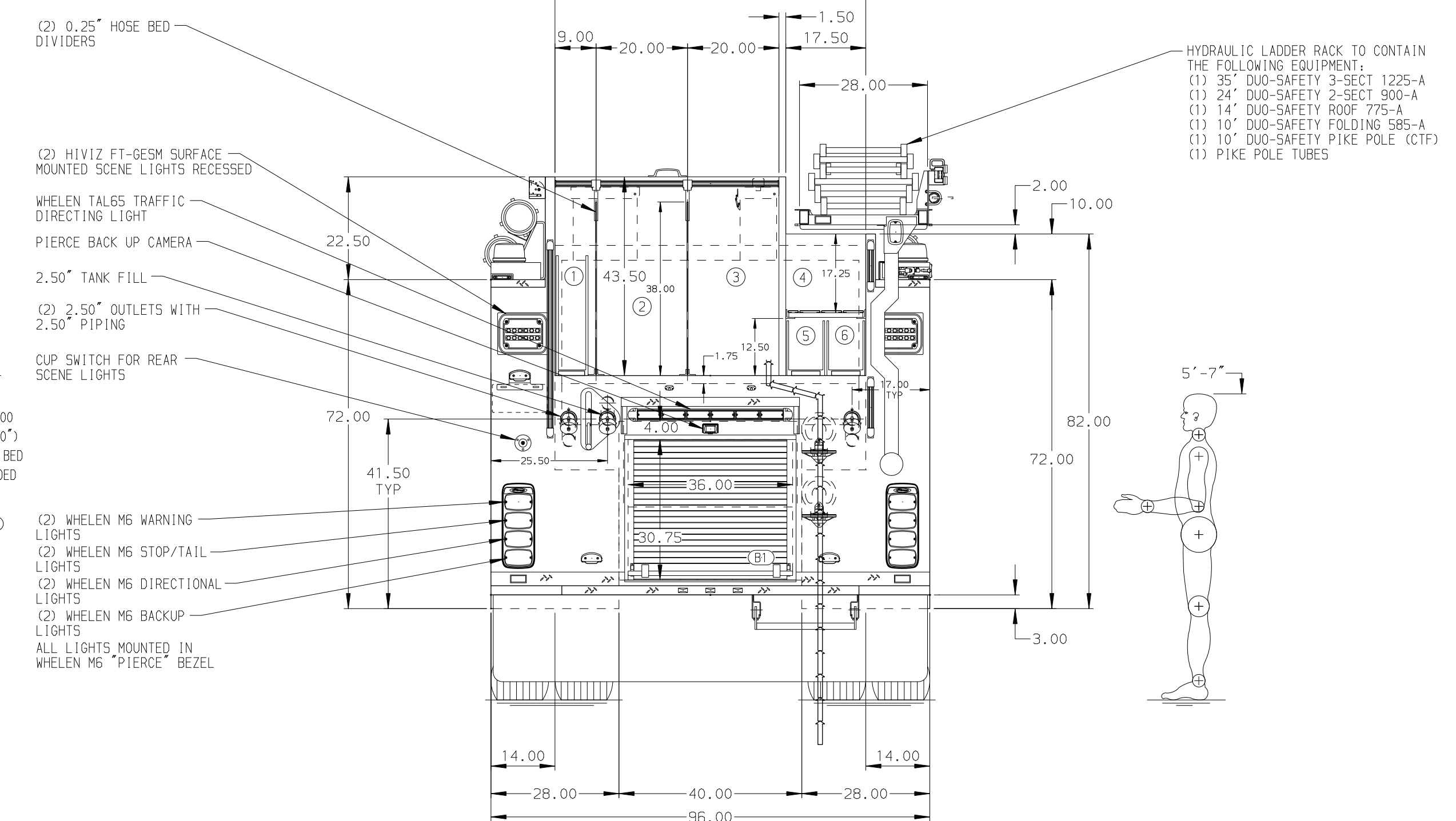
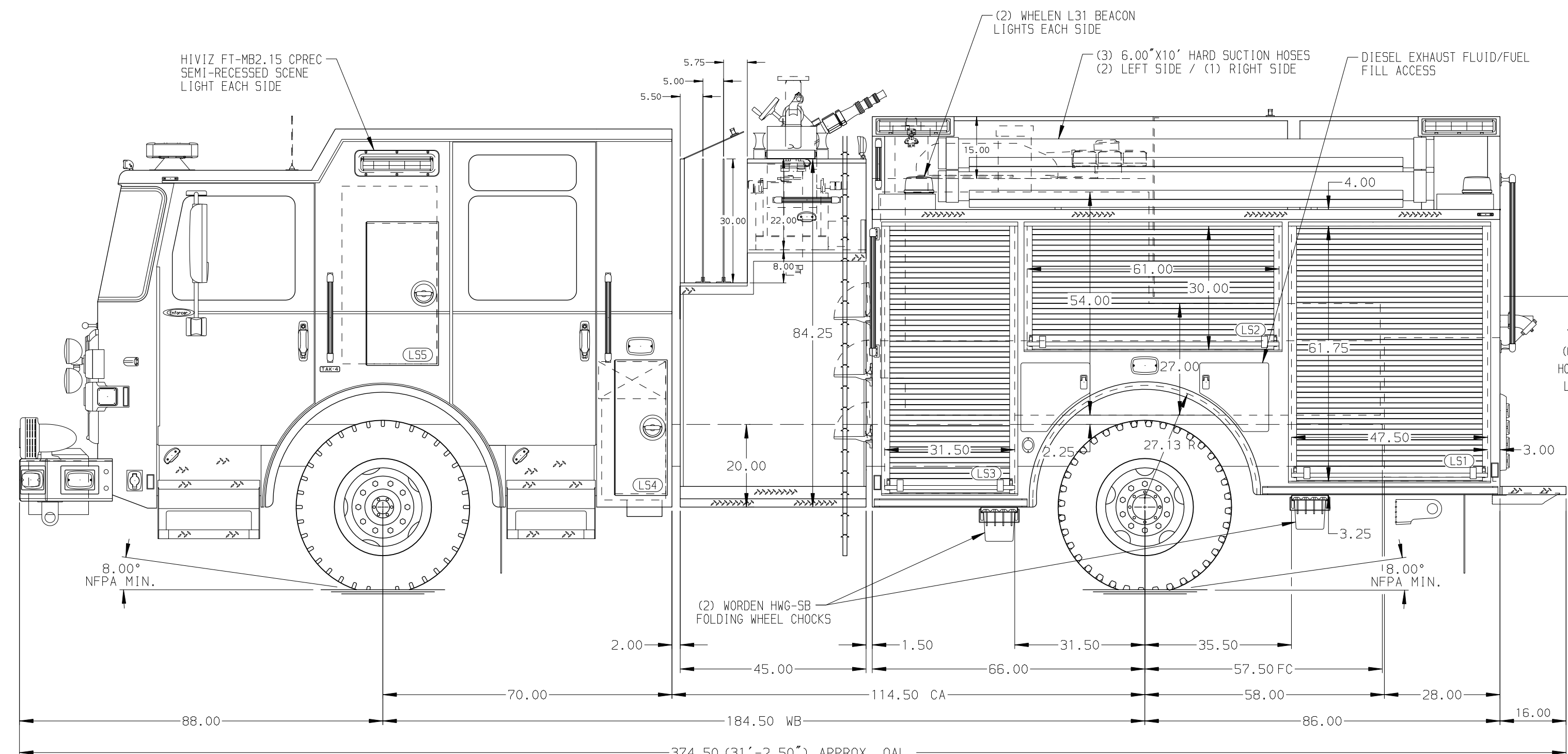

ALUMINUM BODY SIDE ROLL AND FRONTAL IMPACT PROTECTION

NOTE
 DIMENSIONS SHOWN ARE APPROXIMATE AND ARE SUBJECT TO MINOR DEVIATIONS AS MAY OCCUR OR BE NECESSARY IN CONSTRUCTION. MINOR DETAILS NOT SHOWN.

- 1. AIR INLET WITH DISCONNECT FITTING LOCATED AT LEFT SIDE PUMP PANEL
- 2. BATTERY CHARGER LOCATED IN COMPARTMENT-RS3

		JOB NO.	38757
		SCALE	DATE
Pierce MANUFACTURING INC.		DRAWN BY	BST
TITLE 2000GPM, 1000G TANK, 970G WATER, 30G FOAM 152" PUMPER BODY, HARD WIRED		CHECKED BY	CDU
FOR NEW MARTINSVILLE FIRE DEPARTMENT NEW MARTINSVILLE, WEST VIRGINIA		SHEET SIZE	SHEET NO.
DWG NO.		38757AD	
REV DATE BY CH ENFORCER		1 OF 1	

REV	DATE	BY	CH	ENFORCER
21MAY24	BST	JGO		
26APR24	BST	JGO		
15MAR24	CDU	SJS		