

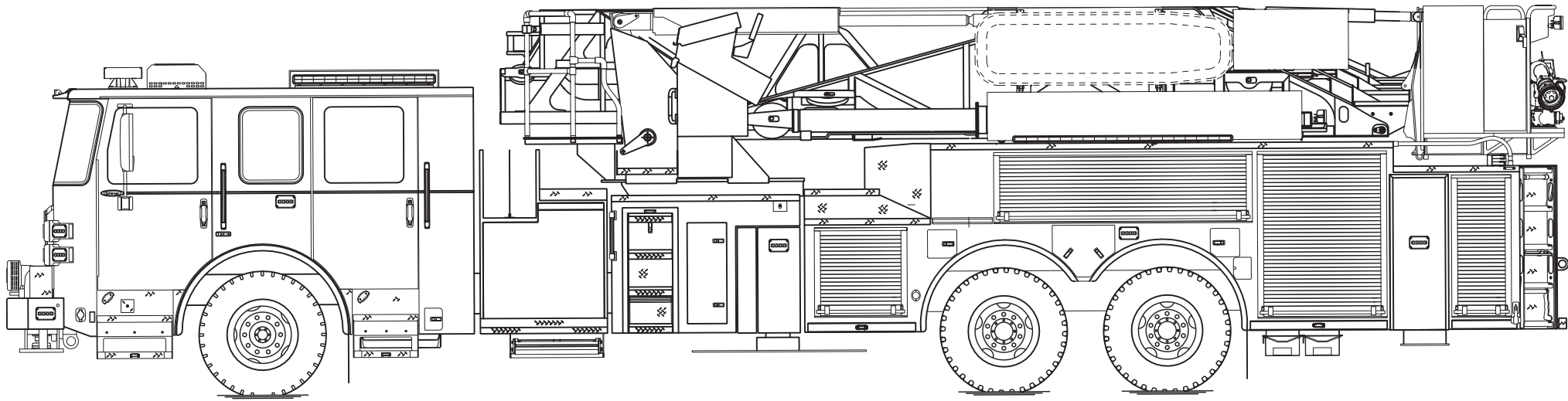

PERFORM. LIKE NO OTHER.™

# Enforcer™ Ascendant® 100' Heavy-Duty Aerial Tower



## Chassis

Chassis	70" <b>Enforcer</b> cab
Seating Capacity	6
Overall Height	11' 4"
Overall Length	43' 0.25"
GVW Rating	76,640 lb
Safety	<b>Side Roll and Frontal Impact Protection</b>
Front Axle	<b>TAK-4® Independent Front Suspension</b> , 24,000 lb
Rear Axle	<b>TAK-4 T3™ Independent Rear Suspension</b> , 52,640 lb
Engine	<b>PACCAR MX13</b> , 510 hp, 1850 lb-ft
Electrical System	<b>Command Zone™ Advanced Electronics System</b>

## Body

Material	Aluminum
Shelving	Adjustable, up to 500 lb
Doors	Rollup
Pump	Waterous, 2,000 gpm
Tank	300 gallons
Pump Panel	<b>Pierce® Control Zone™</b> 42" pump panel

## Aerial Device

Device	<b>Ascendant 100' Heavy-Duty Aerial Tower</b>
Reach	100' vertical 93' horizontal
Tip Load	1,000 lb dry 500 lb wet
Equipment	150 lb allowance
Flow Rate	2,000 gpm
Stabilizers	1 set extending 18' spread 4 down-jacks

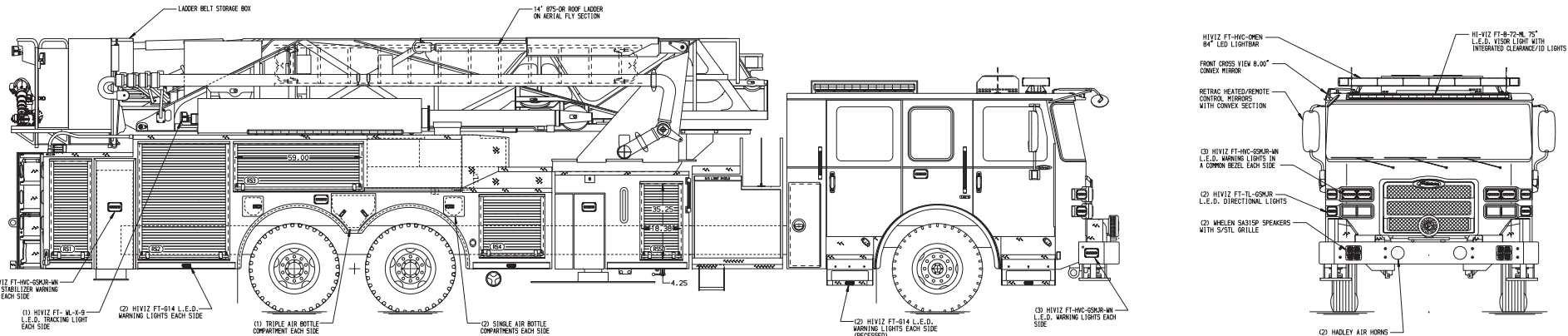

<b>BODY</b> 100' Ascendant Aerial Tower Alum Body COMPT, DRIVER SIDE Full Height Rollup Doors COMPT, PASSENGER SIDE Full Height Rollup Doors	<b>WATER TANK</b> 300 Gallon Poly Water Tank Foam System Foam System Not Required Foam Cell Foam Cell Not Required
---	---

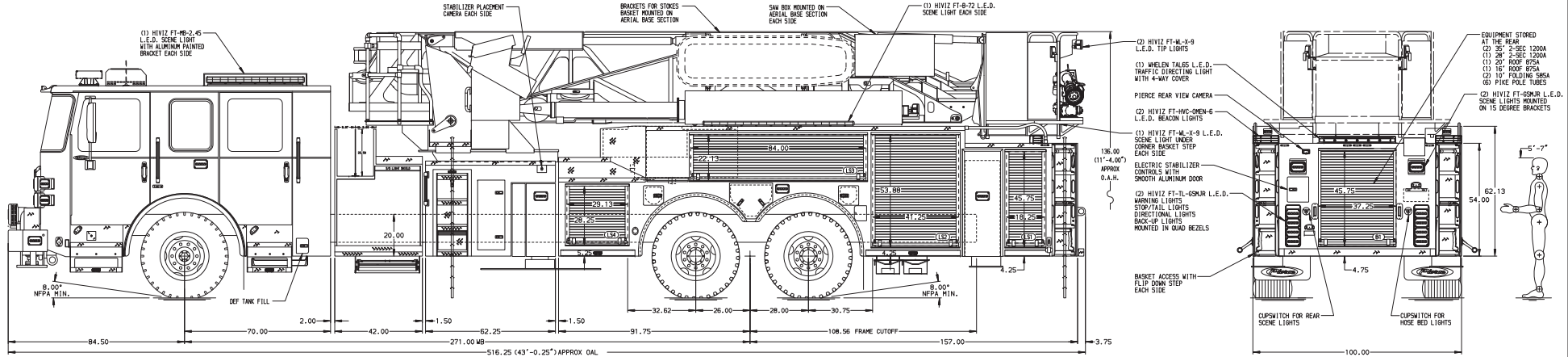
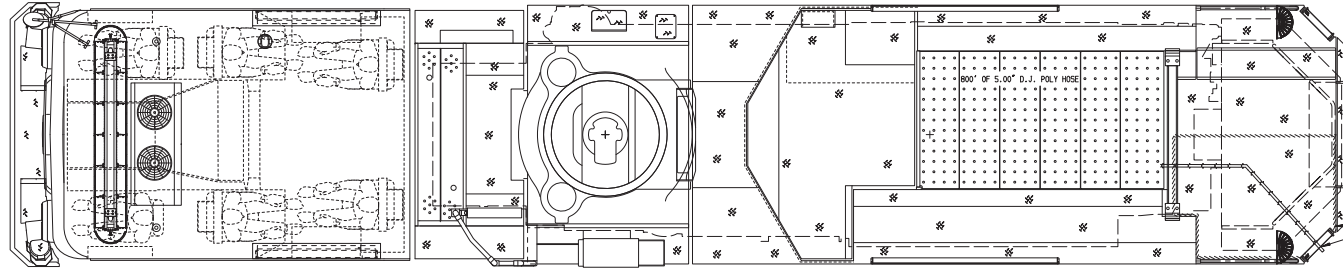

<b>CHASSIS</b> Enforcer Chassis 510 HP Paccor MX13 Engine	<b>CAB</b> 7000 Enforcer Cab BUMPER 15\"/>	
<b>AXLE, FRONT, CUSTON</b> 24,000 Lb TAK-4 Axle	<b>TRANSMISSION</b> Allison 6th Gen, 4500 EVS P	<b>PUMPHOUSE</b> 42\"/>
<b>AXLE, REAR</b> 52,640 Lb TAK-4 T3 Axle	<b>CROSSLAYS, 1.50"</b> (2) 1.50\", 200\"/>	
<b>SAFETY</b> Side Roll and Frontal Impact Protection	<b>CUSTOMER APPROVAL</b> APPROVED BY: DATE: 26AUG24 REV: 1	<b>PIERCE MANUFACTURING INC.</b> JOB NO. 42506 SCALE 1:24 DATE 15JUL24 DRAWN BY ANZ CHECKED BY AST 24JUL24 SHEET NO. 1 OF 1

**NOTE**  
DIMENSIONS SHOWN ARE APPROXIMATE AND ARE SUBJECT TO MINOR DEVIATIONS AS MAY OCCUR OR BE NECESSARY IN CONSTRUCTION.  
MINOR DETAILS NOT SHOWN.

- SHOULDER RECEPTACLE WITH KUSSMALL SUPER AUTO-EJECT LOCATED ON DRIVER SIDE FRONT CORNER OF THE CAB
- AIR BREATHER WITH DISCONNECT COUPLING IN A RECESSED ALUMINUM THEATREPLATE BOX IN THE DRIVER SIDE STEPMALL
- BATTERY CHARGER LOCATED IN DRIVER'S SEAT
- FIVE ADJUSTABLE FULL MOUNTAIN BELT SHIELDS IN COMPARTMENTS PER ORDER
- FOUR SLIDE-OUT FLOOR MOUNTED TRAYS IN COMPARTMENTS PER ORDER
- DUAL LIGHT STRIPS LOCATED IN COMPARTMENTS PER ORDER
- ONE SLIDE-OUT ALUMINUM TOOLBOARD LOCATED IN COMPARTMENT PER ORDER
- ONE POWER TO KEYS, TIP
- 3-IN-1 LITECOBID BRACKETS AT AERIAL BASKET
- TECHNO RING LIGHTING ON AERIAL LADDER
- 2-WAY INTERCOM SYSTEM BETWEEN AERIAL TIP AND TURNABLE
- NON-RAISED AERIAL PEDESTAL

**CHASSIS DATA**  
MAKE PIERCE  
MODEL  
DWG NO. 42506AD

**TITLE**  
100' ASCENDANT AERIAL TOWER AND BODY ASSEMBLY  
FOR PIERCE FIELD UNIT  
APPLETON, WI